

UNIT LEARNING PACKS

# FOCUS IN ACTION

## **Grade 8 Science Focus**

Unit 4 - Mechanical Systems

## ‘Focus in Action’ UNIT LEARNING PACKS

These booklets are designed to provide Grade 8 students with all the resources needed to review or reinforce concepts, covered in the Alberta Science Curriculum, and included in the Grade 8 Science Final Exam in June. There are circumstances in which **an entire unit** may be missed and covering the concepts from that unit (for the final exam) can be difficult. This can happen for a number of reasons:

- Students – new to the school – register throughout the year (from other provinces, school jurisdictions or countries)
- Students may be ill or have surgery and often can miss one or more units
- Students have extended holidays throughout the year
- Transfers from another school, who have completed the units in a different order

For additional support, students are directed to the **Edquest Middle School Science Website** or, Scienceman Resource ([www.scienceman.com/scienceinaction/pgs/hot\\_8u1.html](http://www.scienceman.com/scienceinaction/pgs/hot_8u1.html))

### *Unit 4 – Mechanical Systems*



- **Topic 1 Notes & Quiz** (Page 4)
- **Topic 2 Notes & Quiz** (Page 9)
- **Topic 3 Notes & Quiz** (Page 12)
- **Topic 4 Notes & Quiz** (Page 14)
- **Topic 5 Notes & Quiz** (Page 18)
- **Topic 6 Notes & Quiz** (Page 21)
- **Topic 7 Notes & Quiz** (Page 23)
- **Topic 8 Notes & Quiz** (Page 27)
- **Unit Summary** (Page 29)
- **Review Booklet** (Page 30)  
(Covered in class, prior to the Final Achievement Exam)
- **Unit 1 – Mechanical Systems Test** (Page 37)
- **Answer Key for Section Quizzes and Unit Test** (Page 44)

#### **The Elements of Machines**

<http://www.mos.org/sln/Leonardo/InventorsToolbox.html>

Additional support will be provided, in the form of practice Achievement Test Questions, during the course review in June. Multiple Choice Questions and Numerical Response Questions will be reviewed, as these are the types that will make up the Science 8 Final Exam

Handouts and other activities, to reinforce the concepts covered in this Unit, will be made available based on need. If you require further information or resources, email Edquest directly: [edquest@gmail.com](mailto:edquest@gmail.com).

**Finding Solutions to Problems, instead of Making Excuses**

## Student Instructions for use of this Learning Pack

The purpose of this Learning Unit Pack is to provide you with the resources that will help you cover the material from the curriculum that will be tested on the Final Exam in June. Follow these steps to successfully complete this Unit Learning Pack:

**Step 1** – Read the **Topic Notes**

**Step 2** – Use a **highlighter** to identify the key words or phrases in the Topic Notes and reread the material again paying close attention to those words that you highlighted. If necessary, modify your highlights to make sure you understand the material in the notes.

**Step 3** – Complete the **Topic Quiz**

**Step 4** – Correct the Topic Quiz by **checking the answers** in the back of this Learning Pack.

**Step 5** – Using your **textbook** and the **completed quiz**, find the page where the question and correct answer can be found and write it next to the question number in your Learning Pack.

**Step 6** – **Repeat Steps 1-5** for each of the other Topics in this Unit.

**Step 7** – Look over the **Unit Outline** to review the **Key Concepts** once you have completed all of the Topics.

**Step 8** – Complete the **Unit Review**, using your **Learning Pack** and **Textbook**.

**Step 9** – **Highlight** those sections of the Review that you had difficulty with and review those sections with your teacher prior to taking the Unit Test.

**Step 10** – Take the **Unit Test** and correct it using the answer key provided in the back of the Learning Pack.

**Step 11** – You should now be ready to answer any questions on the **Final Exam** related to this Unit.

Anything you still do not understand should be discussed with your teacher. Congratulations on your **Independent Study**, and Good Luck on the Final Exam. I hope you have made good use of this resource. Please provide feedback to your teacher, so that this resource can be improved.

Additional support is available in the form of practice Achievement Test Questions. **Multiple Choice Questions** and **Numerical Response Questions** will be made available on request, as these are the types that will make up the **Science 8 Achievement Exam**.

Handouts and other activities, to reinforce the concepts covered in this Unit may be acquired by visiting the Edquest Middle School Science Resource Website

<http://www.edquest.ca>

## Topic 1 – Levers and Inclined Planes

**Lever** – is a rigid bar or plank that can rotate around a fixed point called a pivot, or fulcrum. Levers are used to reduce the force need to do a particular task. You can move a very large load, but you must move a greater distance than the load moves.  
<http://207.10.97.102/elscizone/lessons/land/simplmachines/3classes.htm>

The **fulcrum** supports the load. The force exerted on the lever to make it move is called the **effort force**. The mass of the object lifted by the lever is called the load. There are 3 classes of levers. (a pry bar can be all three classes of lever, depending on how it is used.)

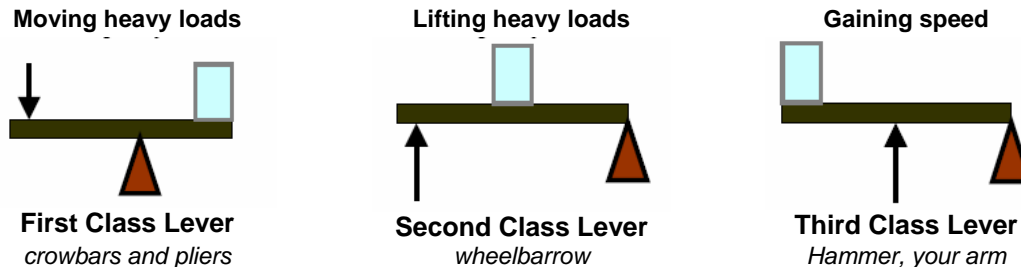

The distance between the fulcrum and the effort force is called the effort arm. The distance between the fulcrum and the load is called the load arm.

### Bones and Muscles: Built-in Levers

Most of the levers in your body are **3<sup>rd</sup> class levers**, but there are 1st and 2nd class levers as well. Your bones act as levers with the joints acting as the fulcrum. Tendons exert the effort force on the bone. The load is what is being moved. **(See the examples in SF text p. 274)**

*This website gives a detailed description of how the bones and joints act as different types of levers.*  
<http://www.horton.ednet.ns.ca/staff/selig/IDU/jointmachine.htm>

### An Arm in Space

Since its maiden voyage aboard [U.S. Space Shuttle Columbia in 1981](#), the Shuttle Remote Manipulator System (SRMS), has demonstrated its reliability, usefulness, and versatility and has provided strong, yet precise and delicate handling of its payloads.



Usually called the Canadarm 1 - the Space Shuttle Remote Manipulator System is an application of levers in space technology. It has been used in different Space Shuttles to help launch and retrieve satellites or repair the Hubble Space Telescope from the shuttle's cargo bay.

A more complex version – Canadarm 2 - has been installed on the International Space Station – It is the Mobile Servicing Station component of the Space Station.



## What is Work?

Scientifically, work is done when a force acts on an object to make that object move. In order to say that work is being done, there must be movement. If there is no movement, no matter how much force is used, no work is done.

Direction of the force applied to an object

Direction of movement as a result of the force being applied to the object



For example; a worker uses force to move a large carton up a ramp. Energy (pushing) is transferred to the carton from the worker. Thus, we say that the worker did work on the carton as long as the carton moved up the ramp as a result of the worker's pushing action (force).

## Calculating Work

The amount of work is calculated by multiplying the force times the distance the object moves. The formula looks like this:  $W = F \times d$

Force is measured in Newtons and distance is measured in meters. The resulting work unit is called a joule, named after the English scientist James Joule.

## Energy and Work

Energy and work are closely related, because without energy there would be no work. Work is done when there is a transfer of energy and movement occurs. Energy provides the force needed to make an object move. The energy can be in the form of human energy (muscle power – chemical reactions in the body producing energy) or it can be in the form of another energy source, such as gasoline (for a car). A machine transfers energy from its source to the object, causing the object to move. There is a very complicated chain of events that make a car move - beginning with it being fueled up with gasoline - all the way through its many subsystems (each doing work) - to eventually the tires rotating to make the car move forward or backward.

## Work and Machines

There are different types of simple machines that can help us do work. The work done with a machine is the same as the work done without it. This can be shown by calculating work input and work output.

**Work input** is the work needed to use, or operate the machine

$$\text{Work}_{\text{input}} = \text{Force}_{\text{input}} \times \text{d}_{\text{input}}$$

**Work output** is the work done by the machine.

$$\text{Work}_{\text{output}} = \text{Force}_{\text{output}} \times \text{d}_{\text{output}}$$

## Work and Friction

Friction is the reason that work input does not equal work output in real situations. Friction affects the machine's efficiency. Efficiency can be calculated using work input and work output.

$$\text{Efficiency} = \frac{\text{Work}_{\text{output}}}{\text{Work}_{\text{in}}} \times 100$$

## Inclined plane

Or ramp, makes it easier to move a load higher than it is, but, it has to be moved over a much longer distance. An inclined plane makes it possible to lift heavy objects using a smaller force (examples: loading ramp, wheelchair access ramp)

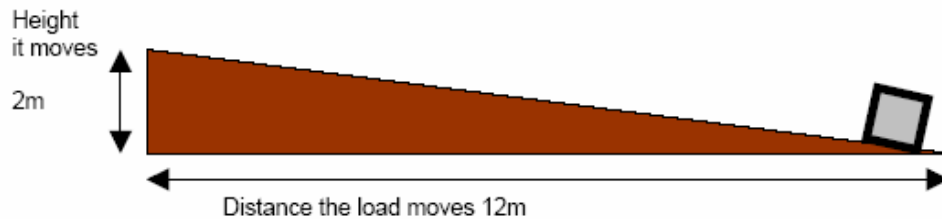

## Mechanical Advantage

Mechanical Advantage is the comparison of the force produced by a machine to the force applied to the machine. (the size of the load vs the size of the force needed to move the load)

$$\text{Mechanical Advantage (MA)} = \frac{\text{Load Force}_{(FL)}}{\text{Effort Force}_{(FE)}}$$

There are *examples* in the textbook to help you practice this calculation (SF p. 278-279)

## Another Way to Calculate Mechanical Advantage

The concepts of mechanical advantage and work can be linked.

$$\text{Mechanical Advantage (MA)} = \frac{\text{Load Force}_{(FL)}}{\text{Effort Force}_{(FE)}} = \frac{\text{Effort Arm}}{\text{Load Arm}}$$

$$(\text{MA}) = \frac{\text{Effort Arm}}{\text{Load Arm}}$$

## Speedy Levers

Speed is the rate of motion that an object changes position. Class 3 levers are not very useful for decreasing the effort force, but rather they are useful because they provide a speed advantage. Effort is produced that moves the load very quickly over a relatively large distance.



*Change the direction of a force (a pulley on a flagpole)*



*Multiply force (a screwdriver)*



*Increasing or decreasing speed (scissors)*



*Transferring force (removing staples)*

See also the review notes here: [http://www.connect.ab.ca/~lburns/students\\_eightunit2notes.html](http://www.connect.ab.ca/~lburns/students_eightunit2notes.html)

## Machines Made to Measure

Body weight, height, size, age and gender are factors taken into account when designing products for use by the consumer. The science of designing machines to suit people is called '**ergonomics**'. Ergonomics is especially important in the design of work environments where occupational safety is an issue. Carpal tunnel syndrome causes numbness and pain in the thumb and first three fingers, caused by the continuous repetitive movements of the fingers on the computer keyboard.

Ergonomically designed products include:



Spacesuit



Infant Car Seat



Assembly Line

## Mechanical Systems

### Topic 1 – Levers and Inclines Planes Practice Quiz

1. A wheelbarrow is an example of what simple machine?
  - A. Class 1 lever
  - B. Class 2 lever
  - C. Winch
  - D. Inclined plane
2. The Canadarm is an example of what simple machine?

- A. Class 1 lever
- B. Class 2 lever
- C. Class 3 lever
- D. Class 4 lever



3. Use the following Diagram for this Question.



- In the lever above, the effort force is applied at E. This makes it a ...
- A. Class 1 lever
  - B. Class 2 lever
  - C. Class 3 lever
  - D. Class 4 lever
4. Calculate the mechanical advantage, when 736 N of force is used on a bicycle pedal, causing 81 N of force to move the bicycle forward.
    - A. 917
    - B. 655
    - C. 9.08
    - D. 0.11
  5. A simple machine that converts rotational motion to linear motion is called ...
    - A. Inclined plane
    - B. Wedge
    - C. Screw
    - D. Class 2 lever
  6. The science of designing machines to suit people is called ergonomics. The primary criteria used in designing a machine ergonomically is ...
    - A. Size
    - B. Aesthetics
    - C. Expense
    - D. Comfort



## Topic 2 – The Wheel and Axle, Gears and Pulleys

### A Lever That keeps on Lifting



A winch consists of a small cylinder that has a crank or handle. The axle of the winch acts like the fulcrum, the handle is the effort arm. By exerting a force on the handle to turn the wheel the cable is retracting the load. Because the handle is longer than the radius of the wheel, the effort force is smaller than the load – making it act like a small lever over and over again.

The **Wheel and Axle** is a combination of two wheels of different diameters that turn together - a lever that rotates in a circle around a center point or fulcrum. A longer motion on the wheel produces a more powerful motion on the axle, thus giving it a **mechanical advantage** (steering wheel in a car). Several simple machines all working together in a system are called **complex machines**. A **system** is a group of parts that work together to perform a function. A wheel and axle can be also be used to increase the speed (bicycle wheels) for a **speed advantage**.

The bicycle is a good example of a complex machine because it is a system for moving a person from one place to another. Within the bicycle are groups of parts that perform specific functions, such as braking or steering. These groups of parts are called **subsystems**. Each subsystem in a complex machine contains a simple machine and usually has just one function.

The subsystems of a bicycle are:

- Wheel and axle
- Drivers & Gears
- Frames & Materials
- Brakes & Steering
- Aerodynamic design

Explore the Science of Cycling at this website:  
<http://www.exploratorium.edu/cycling/index.html>

Build your Dream Bicycle:

<http://www.thetech.org/exhibits/online/topics/54j.html>

The subsystems in a mechanical device that produce motion, such as in a bicycle, play a role in how energy is transferred within the system. The subsystems are called linkages and transmissions.

### Linkages

The linkage is the part of the subsystem that transfers your energy from the pedals to the back wheel. In the bicycle, the chain is the linkage. In a car, the fan belt is the linkage from the engine to the cooling fan – to prevent the engine from overheating. Chains or belts form a direct link between two wheels – one that drives the motion and the other will follow in the same direction.

### Transmissions

Machines that are more complex than a bicycle move much larger loads. A special type of linkage is needed. It is called a transmission. It transfers energy from the engine to the wheels. A transmission contains a number of different gears. This enables the operator to move the object slowly with a large force, or quickly with a smaller force

### Gears

Gears are essential components of most mechanical systems. They consist of a pair of wheels that have **teeth that interlink**. When they rotate together, one gearwheel transfers turning motion and force to the other. There are many different types of gears.

This website has just a few: <http://www.fi.edu/time/Journey/Time/Escapements/geartypes.html>

## Gearing Up

Gears transfer energy in a mechanical system. Gear wheels – which are wheels with precisely manufactured, identical teeth around its edge - work together in gear trains of two or more wheels transferring rotary motion and force from one part of a complex machine to another part. A smaller gear (Y) is called a **pinion**. The gear that supplies the energy is called the **driving gear** (X). The gear to which the force is directed is called the driven gear (Y).

## Going the Distance

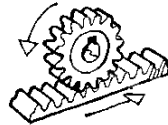
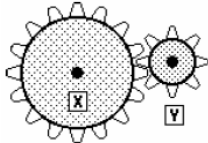

Rack and Pinion Gear

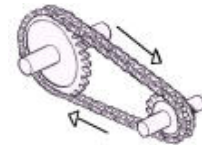

Chain and Sprocket

A **large gear (X) driving a smaller gear (Y)** decreases torque and increases speed in the driven gear. Gears such as these are called multiplying gears.

A **small gear (Y) driving a larger gear (X)** increases torque and reduces speed in the driven gear. Gears like these are called reducing gears. When the driving gear has fewer teeth than the driven gear, the driven gear then rotates more slowly than the driving gear. A car or bicycle in low gear uses reducing gears.

When the driving and the driven gears are the same size they are known as parallel gears. The relationship between the speed of rotations of a smaller gear and a larger gear is called speed ratio. It can be calculated by dividing the number of driver gear teeth by the number of follower gear teeth.

A **Pulley** consists of a wire, rope, or cable moving on a grooved wheel. One or more combinations of wheels and ropes can be fixed in place or moveable.

Pulleys help you lift larger loads.

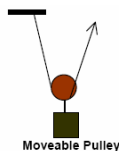

Moveable Pulley

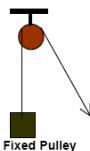

Fixed Pulley



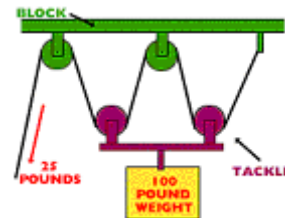

## Supercharging Pulleys

A very complex combination of pulleys, including fixed and moveable is called a block and tackle.

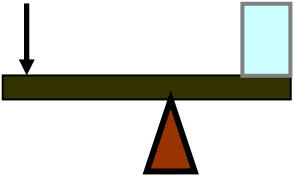
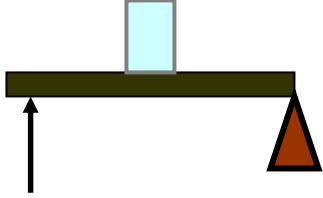
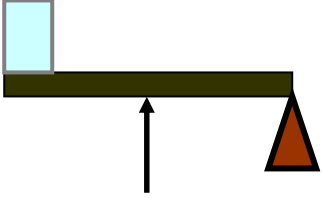
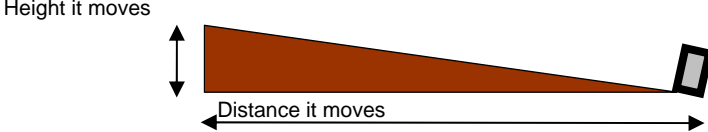
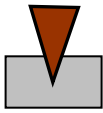

Depending on the number of pulleys used, a block and tackle can have a large mechanical advantage.

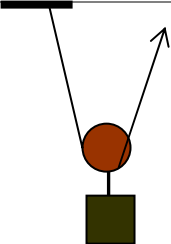
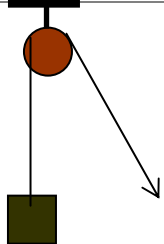
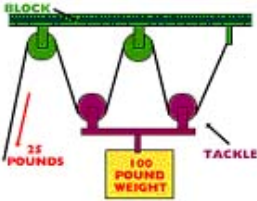
**Simple Machines (a brief summary)**

SIMPLE MACHINE	Function & Action	Applications
<b>LEVER</b>	A stiff bar resting on a fulcrum - lifts or moves loads	Shovel, nutcracker, seesaw, crowbar, elbow, tweezers
<p><b>Moving heavy loads</b></p>  <p><b>First Class Lever</b> <i>crowbars and pliers</i></p>	<p><b>Lifting heavy loads</b></p>  <p><b>Second Class Lever</b> <i>wheelbarrow</i></p>	<p><b>Gaining speed</b></p>  <p><b>Third Class Lever</b> <i>Hammer, your arm</i></p>
<b>INCLINED PLANE</b>	A slanted surface connecting a lower level to a higher level Things move up or down it	Slide, stairs, , ramp, escalator, slope
		
<b>WEDGE</b>	An object with at least one slanted side ending in a sharp edge Cuts or spreads an object apart	Knife, pin, nail, chisel, axe, snowplow, front of a boat
<p>W E D G E</p> 	<p>S C R E W</p> 	
<b>SCREW</b>	An inclined plane wrapped around a pole that holds things together or lifts	Screw, jar lid, vise, bolt, drill, corkscrew
<b>PULLEY</b>	A grooved wheel with a rope or cable around it, moving things up, down, or across	Curtain rod, tow truck, mini-blind, flag pole, crane
 <p><b>Moveable Pulley</b></p>	 <p><b>Fixed Pulley</b></p>	 <p><b>Block and Tackle</b></p>
<b>WHEEL and AXLE</b>	A wheel with a rod (axel) through its center: both parts move together to lift or move loads	Car, wagon, door knob, pencil sharpener, bike, screwdriver
		

## Mechanical Systems

### Topic 2 – Wheel and Axle Practice Quiz

- A device that consists of a small cylinder, with a handle or a crank is called a ...
  - Radius
  - Winch
  - Fulcrum
  - Pinion
- Gears are used in combination, with the teeth of the gears interlocking, so when one moves the other moves as well. Effort can be applied to the first gear (24 teeth), with the resulting effect on the second gear (12 teeth) being ...
  - Speed advantage of 0.5
  - Speed advantage of 2
  - Force advantage of 2
  - Force advantage of 0.5
- When gears are used in a gear train, the resulting effect is that each gear travels ...
  - Slower than the one next to it
  - Faster than the one next to it
  - In an opposite direction than the one it is nearest to
  - Always in the same direction as the one next to it
- The mechanical advantage of the block and tackle (complex combination of fixed and moveable pulleys) pictured here is ...

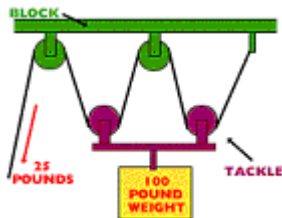

- 3
  - 4
  - 5
  - 6
- The pedals on a bicycle are attached to sprocket gears which are linked together by a chain. The type of energy that describes the motion created when you apply force to the pedal is ...
    - Gravitational
    - Frictional
    - Potential
    - Kinetic

## Topic 3 – Energy, Friction, and Efficiency

### Work and Energy

Machines help people do things that they normally couldn't do on their own. **Work** is a transfer of energy. In the example of the bicycle – your energy (chemical energy from your food) is transferred to the pedals giving them **kinetic energy**, or energy of motion. The pedals transfer this energy to the sprockets and chain, and then to the wheels.

### Stored Energy

Stored energy is called **potential energy**. Much of the energy for machines is stored as chemical potential energy. Gravitational potential energy is transferred to kinetic energy in machines in a dam to generate electrical energy.

Another example of **potential gravitational energy** is the water cycle.

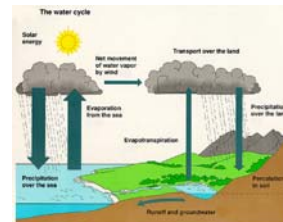

### Energy Transmitters

In energy **transmission**, the energy is transferred from one place to another, and no energy is changed or converted.

***Energy cannot be created nor destroyed – It is only transformed or transferred***

### No Machine is 100% Efficient

An ideal machine would transfer all the energy it received to a load or to another machine. However there are no ideal machines. Real machines lose energy. The work output of a real machine is always less than the work input. **NO MACHINE IS 100% EFFICIENT**. The *efficiency* of a machine tells you how much of the energy you gave to the machine is actually transferred to the load. **Efficiency** is a comparison of the useful work provided **by** a machine or a system with the work supplied **to** the machine or system.

$$\text{Efficiency} = \frac{\text{Work done by machine}}{\text{Work done to make the machine operate}} \times 100\%$$

The higher the efficiency, the better the machine is transferring energy. The reason that machines are never 100% efficient is because of the energy that is lost by a machine to **friction**.

### Boosting Efficiency

Since some of the effort force put into a machine is used to overcome the frictional force of the machine, there are ways to boost the efficiency of a machine. Lubricants, reducing the surface area interaction where parts rub together and good maintenance of the machine will help to reduce friction and increase efficiency.

### Useful Friction

There are reasons why we need friction in a machine for it to perform properly. Slipping and sliding would occur and proper gripping would be impossible without friction. There are many places where friction is useful, including:

- Bicycle – tires create friction with the road surface to give you grip
- Baseball – **rosin** is used to form a stronger grip with the bat
- Gymnasts – also use **rosin** to provide grip on slippery metal surfaces (like rings or bars)
- Curlers – sweep the ice in front of the rock to decrease friction with the ice surface

## Mechanical Systems

### Topic 3 – Energy, Friction and Efficiency Practice Quiz

1. ( **Efficiency = work output / work input** ) A pulley system lifts a 100N load with a force of 20N. The input distance is 3m and the output distance is 0.5m. The efficiency of this pulley system is ...
  - A. 62.5%
  - B. 75.0%
  - C. 83.3%
  - D. 92.75%
2. Efficiency can be increased by reducing frictional force. A sport that tries to reduce frictional force by sweeping the ice in front of the rock is ...
  - A. Cycling
  - B. Curling
  - C. Rock climbing
  - D. Ice sculpturing
3. When a skater moves across an ice surface, a thin layer of water is created, allowing the skate blade to slide across the surface with little friction. This layer of water is produced by the pressure of the ...
  - A. Zamboni
  - B. Atmospheric pressure
  - C. Skate blade
  - D. Ice temperature
4. The process which transfers energy or power from one place to another is 'energy ...'
  - A. Conversion
  - B. Transformation
  - C. Transmission
  - D. Convection
5. Gymnasts rub chalk powder (called rosin) on their hands prior to competing. They do this to ...
  - A. Decrease friction
  - B. Increase friction
  - C. Increase efficiency
  - D. Decrease efficiency

## Topic 4 – Force, Pressure, and Area

### Calculating Pressure

Pressure is a measure of the amount of force applied to a given area.

$$p = F / A$$

**p** is pressure **F** is Force and **A** is Area

The unit of measurement for pressure is a Pascal (Pa), named after Blaise Pascal who did important research on fluids.

1 Pascal is equal to the force of 1 Newton over an area of 1 m<sup>2</sup>  
1 Kilopascal is equal to 1000 pascals

### Equipped Against Pressure

Safety equipment is need in many situations in order to protect our body from injury or accident. Most of the safety equipment is designed *to spread the force over a larger area*.

### Pascal's Law

Blaise Pascal (1623-1662) discovered that ...

*Pressure applied to an enclosed fluid is transmitted undiminished in all directions throughout the fluid and perpendicular to the walls of the container.*

This is known as **Pascal's Law** and it makes **hydraulic** (liquid) and **pneumatic** (air) systems possible.

He was the first to notice that the shape of the container had no effect on the pressure at any given depth as illustrated here.

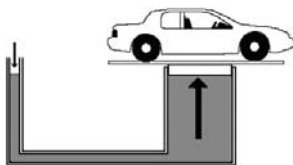

A common application of Pascal's law is the *hydraulic lift*.

It is a mechanical system that raises heavy objects, using a fluid under pressure in a *closed system* (self-contained collection of parts).

## Pascal's Law and Mechanical Advantage

$$\text{Mechanical Advantage} = \frac{\text{Load Force}}{\text{Effort Force}}$$

In hydraulic systems, the pressure is created using a piston. Pistons can be different sizes and hydraulic devices use pistons that are different sizes attached to each other with a flexible pipe. The **input piston** is used to apply force to the fluid, which creates pressure in the fluid. The fluid transfers this pressure to the **output piston**. This pressure exerts a force on the output piston and the result is a mechanical advantage that makes the hydraulic system very useful.

The mechanical advantage in a hydraulic system comes from the fluid pressure in the system.

Calculating the input force and the output force will give you the Mechanical advantage of the system.

$$\text{MA} = \text{Output force} / \text{Input force}$$

$$\text{MA} = F_o \times d_o / F_i \times d_i, \text{MA} = 10 / 1 = 10$$

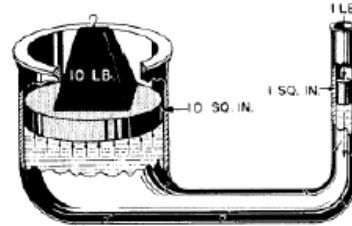

This hydraulic system has a mechanical advantage of 10

Mechanical advantages in hydraulic systems are usually quite high, showing how useful they are.

## Pressure and Mechanical Advantage

The reason for the large mechanical advantage in a hydraulic system is the ability of the fluid to transmit pressure equally. It allows you to use a small force on the small piston to produce a larger force on the large piston.

$$p = F / A$$

From Pascal's law, we know that the pressure the small piston creates is the same everywhere in the fluid. So the large piston has a larger area and is able to multiply the pressure because of its larger area. The force and area at each piston act as ratios that have to be equal.

$$\frac{\text{Force of the small piston}}{\text{Area of the small piston}} = \frac{\text{Force of the large piston}}{\text{Area of the large piston}}$$

$$\frac{F_{\text{small}}}{A_{\text{small}}} = \frac{F_{\text{large}}}{A_{\text{large}}}$$

By solving this ratio you will find that the forces created within a hydraulic system provides very large mechanical advantages - making them useful in many applications.

## Larger Force – Greater Distance To Move

Mechanical advantage in hydraulic systems has a cost. That cost is the increased distance the smaller force must go through to make the large force move a small distance.

***To increase the force on the output piston ,  
the input piston must move through a greater distance.***

Amusement park rides make extensive use of hydraulic systems





## Mechanical Systems

### Topic 4 – Force, Pressure, and Area Practice Quiz

- To calculate pressure the formula used is  $P = F / A$ . Units of pressure are ...
  - Joules
  - Kilojoules
  - Pascals
  - Kilograms
- The heel of a stiletto shoe can exert a lot of pressure. If the area of the heel is  $0.5\text{cm}^2$  and a force of  $200\text{N}$  is exerted using the heel, what is the pressure exerted by the heel?
  - 10 Pa
  - 200 Pa
  - 400 Pa
  - 1000 Pa
- Crash test dummies are used to test safety in vehicles. The main reason for this is because they are ...
  - Inexpensive to use
  - Realistic
  - Easily repaired
  - Non-living
- Pascal's law states that ...
  - Pressure exerted on a contained fluid is transmitted equally in all directions
  - Pneumatics exerted on a contained fluid is transmitted equally in all directions
  - Force exerted on a contained fluid is transmitted equally in all directions
  - Hydraulics exerted on a contained fluid is transmitted equally in all directions
- A cherry picker uses hydraulics to raise a working platform.  $10\text{N}$  of force are applied to the small piston in the hydraulic system to raise a load of  $50\text{N}$  (on the large piston) a distance of  $0.5\text{m}$ . how far would the small piston have to be pushed to accomplish this task?
  - 5 m
  - 2.5 m
  - 0.5 m
  - 25 m

## Topic 5 – Hydraulics and Pneumatics

**Hydraulic systems** use the force of a liquid in a confined space.

Hydraulic systems apply two essential characteristics of fluids – their incompressibility and their ability to transmit pressure.

**Pneumatic systems** do not seal the gas (usually air) in the same way as hydraulic systems seal in the fluid it uses. The air usually passes through the pneumatic device under high pressure and then escapes outside the device. The high pressure air is used to do the work.

### Pneumatics at Work



The jackhammer is an example of a pneumatic device that is used to do work. The loud noise of the jackhammer is the compressed air at work. Bursts of air, under very high pressure drive the 'chuck' in and out of the jackhammer at high speeds, which pounds the concrete – breaking it up into small rocks or fragments.



Staple guns and pneumatic nailers use pulses of air pressure to drive staples or nails into solid objects.



Sandblasters do exactly what the name implies. High pressure air blasts tiny sand particles out of a nozzle to remove dirt and paint from stone or rock. Sandblasting an old building made of stone or brick can make it look almost like new. Sandblasting is also used to roughen surfaces to improve traction, by increasing friction. Medical engineers have developed a type of cast filled with pressurized air, which makes it fit snugly and securely.

### Riding on Air



Hovercrafts are used by the Canadian Coast Guard in search and rescue missions. They are also used commercially, to transport people, cars and equipment over long distances on land or water. The hovercraft has a pump that draws air from outside and pumps it out through small holes in the bottom of the hovercraft. A skirt around the bottom holds enough air to support the weight of the craft above the water or land. Propellers on the back of the craft drive the hovercraft forward, and rudders are used to steer it.

### Hydraulics at Work

Most machines that move very large, very heavy objects use a hydraulic system that applies force to levers, gears or pulleys. A hydraulic system uses a liquid under pressure to move loads. It is able to increase the mechanical advantage of the levers in the machine. Modern construction projects use hydraulic equipment because the work can be done quicker and safer. There are many practical applications of hydraulic systems that perform tasks, making work much easier.



Earthmovers use hydraulics to move large amounts of dirt from place to place.



The cherry picker is an example of a hydraulic device that is used to do raise workers to high places to repair or do work at heights that normally could not be reached safely.

### Hydraulics in Flight

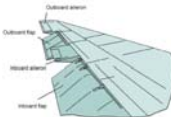

The various parts of an airplane wing are raised and lowered hydraulically. Hydraulics are also responsible for tail adjustments to enable the pilot to turn the plane in the air. Wheels are raised and lowered using a hydraulic system as well. There are different hydraulic systems in different aircraft, but all the systems work together in much the same way to provide reliable and safe adjustments when the plane is taking off, airborne and landing.

### Hydraulics and Pneumatics in Your Body

Life depends on a pneumatic system in your body – namely the respiratory system. The lungs that allow air to enter and leave the body as they contract and expand. Breathing depends on changes in air pressure. You breathe in and out about 12 times a minute, exchanging about 500ml of air each time.

Your body also depends on a complex hydraulic system – the circulatory system. The heart (your hydraulic device) pumps the blood (fluid) around your body carrying food and nutrients to all cells in your body. A review of this body system ([Unit 2 – Topic 6 – Cells and Systems](#)) will help you understand the details.

### Valves and Pumps

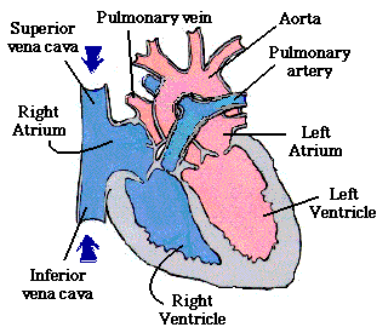

A valve is used to control the flow of a fluid. It is a moveable part that controls the flow by opening or closing. Many pumps use automatic valves controlled by pressure to move fluids in specific directions. Pressure on one side opens the valve and closes when the pressure on the other side is greater.

The heart is actually two pumps that circulate your blood throughout the body. Four automatic valves are used to help circulate the blood. Between heartbeats the pressure changes allowing the valves to open and close when they are supposed to.

## Mechanical Systems

### Topic 5 – Hydraulics and Pneumatics Practice Quiz

1. In the illustration below, the area of the small piston on the left is  $0.5\text{m}^2$  and the area of the large piston is  $5.5\text{m}^2$ .

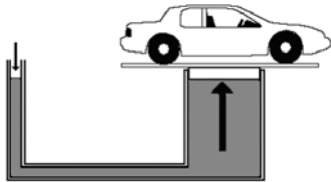

- The mechanical advantage of the illustrated hydraulic lift here would be ...
- 1.1
  - 6.0
  - 2.5
  - 1.1
2. A 'hovercraft' is a ...
- Hydraulic device
  - Pneumatic device
  - Pneumonic device
  - Hydroelectric device
3. A jackhammer is a pneumatic device that is used to break up the cement or concrete. The ear-splitting sound you are hearing is produced by ...
- Anvil
  - Piston
  - The 'chuck'
  - Compressed air
4. A sandblaster is used to improve the look of a building. The high pressure air blasts tiny sand particles to remove the dirt and paint from stone or brick. It is also used on smooth granite and marble stairs to make them ...
- Less shiny
  - Safer by increasing friction
  - Look new
  - Look older than they actually are (antiques)
5. The 'Jaws of Life' used by firemen to rescue people from a crushed car, use three types of tools, including all of the following, EXCEPT ...
- Contractors
  - Spreaders
  - Rams
  - Cutters

## Topic 6 – Combining Systems

As time passed, people expected more and more difficult tasks to be completed by machines. Machines became more complex. Several simple machines all working together in a system are called **complex machines**. A **system** is a group of parts that work together to perform a function. Groups of parts that perform specific functions, in a complex machine, are called **subsystems**. Each subsystem in a complex machine contains a simple machine and usually has just one function.

### Subsystems

The different subsystems in a mechanical device can produce a force advantage, such as the **disc brakes** in a car.

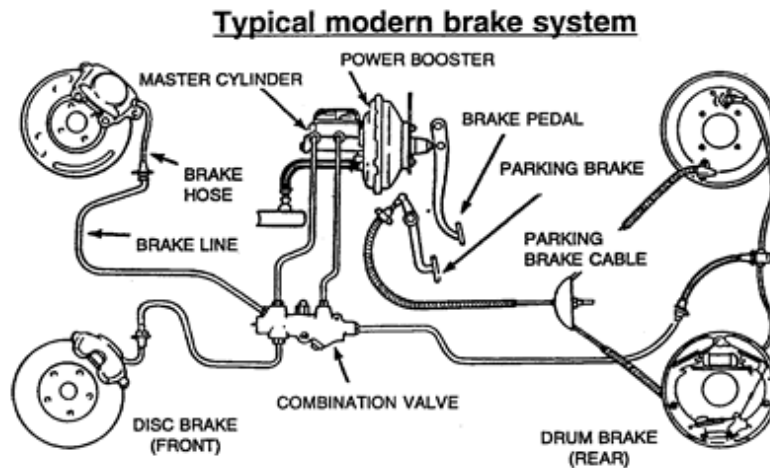

The brake fluid transfers the pressure from the brake pedal to the brake pads and the disc, which produces enough force to stop the car.

Another example of a highly efficient combination of levers and hydraulics is the backhoe.

The backhoe is a combination of 3 levers, called the boom (class 3 lever), the dipper (class 1 lever) and the bucket (class 1 lever).

The assembly of the 3 levers swings around on a gear-like part called the slew ring.

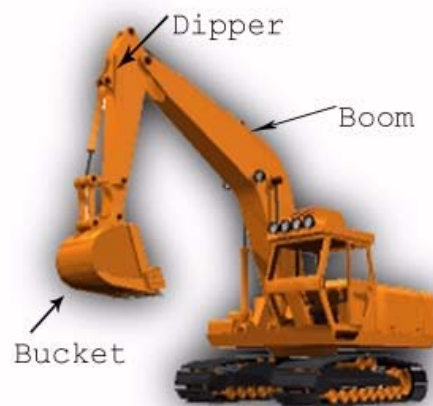

## Mechanical Systems

### Topic 6 – Combining Systems Practice Quiz

1. Use the illustration of a hydraulic disc brake system below to answer the question.

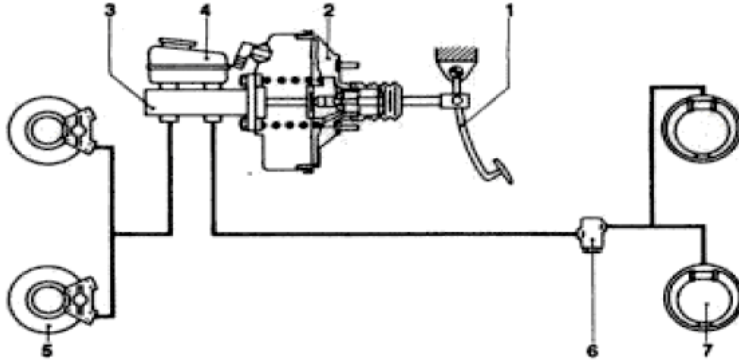

The effort required to slow the vehicle in this disc brake hydraulic system would be applied at number ...

- A. 1
  - B. 3
  - C. 5
  - D. 7
2. During the research phase, when a device is improved upon, certain criteria are taken into account. Of the criteria listed below, which would be the least important ...
- A. Safety
  - B. Efficiency
  - C. Effectiveness
  - D. Convenience
3. The 'backhoe' is a highly efficient combination of 3 different types of levers and this ...
- A. Wheel and axle
  - B. Pulley
  - C. Hydraulics
  - D. Pneumatics
4. When we can identify a simple machine, within a much more complicated machine, the simple machine is called a ...
- A. Segment
  - B. Subsystem
  - C. Function
  - D. Prototype
5. The 'boom' raises and lowers the 'dipper'. It is a ...
- A. Class 1 lever
  - B. Class 2 lever
  - C. Class 3 lever
  - D. Class 4 lever

## Topic 7 – Machines Throughout History

Machines help people use energy more efficiently. The earliest machines were simple devices to make work easier; like moving a large rock or moving a load up an incline, splitting wood or lifting materials up to a working area above the ground. These simple machines depended on people or animals as their source of energy.

Machines were built to satisfy basic human needs, such as getting water. Three devices used to get water in earlier times included:



**Sakia** (or, Persian wheel)



**Roman aquaduct**



**Archimedes screw**

The invention of the **steam engine** in the late 18th century was an important achievement. The steam engine moved goods across countries in a very short time, giving people more and better access to food, clothing, tools and raw materials than previously. The standard of living had improved. It led to many changes in transportation technology and in the way we manufacture products. Factories provided jobs for workers and many people moved to the cities. The continual development of new technologies has led to our virtual dependence on machines.

Different modes of transportation have changed as science and technology have developed.

**Steam Engine**



**Magnetic Levitation Train**

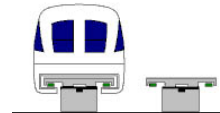

**Canoe**



**Motorboat**



**Dog Sled**



**Ski Doo**



**Horse and Cart**



**Sports Car**



### Putting Steam To Work

Heat-operated mechanical devices have been around for a long time. In 150 B.C.E. Hero of Alexandria in Egypt described many of his mechanical devices that used gears, wheels and axles, pulleys, hydraulics and pneumatics.

Thomas Savery developed the first practical steam engine in 1699. He heated water to make steam and then used it to move a piston. When the piston moved, it caused an attached rod (which was connected to a crankshaft) to move as well, making the engine work.

## Steamboats

The invention of steam engines, also led to innovations in water transportation, like the **paddle-wheeled steamboat**.

These steamboats were used extensively during the fur trade, moving furs and goods throughout the country. They also helped supply the pioneers with farming equipment and supplies, during the early settlement of the prairies.



Steam under high pressure operates the pistons to turn the wheel in the engine.



## Turning Wheels

Paddle-wheeled riverboats are rarely seen today, but steam still powers many **ocean liners**. Steam turns large turbines (rotary engines) which are attached to the propellers, which drive the ocean liner through the water. There are many other uses for turbines, including: toys, jet engines, electricity generators.



## Burning Inside

The desire to improve the steam engine's efficiency led to the development of the internal **combustion engine** in Germany in 1876. The combustion occurs inside the engine. The pistons goes through 4 steps: Intake stroke (taking in the fuel), compression stroke (compressing the fuel-air mixture), power stroke (the fuel-air mixture is ignited), exhaust stroke (waste products are released). The crankshafts change the up-down, or back-forth motion of the pistons to rotary motion, which turns the vehicle's wheels.

## Taking Flight

Early internal combustion engines were used in aircraft, because the steam engine was too heavy and cumbersome. New materials and technology, human and environmental needs all contribute to the development of changes to current devices. When failure occurs, modifications must also be made to ensure the device performs its intended function effectively and efficiently. Trial and error also can play a role in technology development.

## From Particles to Trains

New technology can also develop from unrelated research. The **MAGLEV** (Magnetic Levitation) trains in Japan operate on super-conductive magnets, powered by electricity. They can travel at speeds over 350 km/h floating on the rails. The technology for the MAGLEV resulted from physics experiments using particle accelerators (huge machines used to break apart atoms and other particles of matter) which use large amounts of electricity to create powerful; magnetic and electric fields.



## **Changes in Society Result In New Technologies**

New technology can also result from changes to human society. Robots were originally popularized in movies and comic books. The word robot comes from the Czech word 'robotnik', meaning workers, or slaves. They were thought to be 'human-like' machines that could do the work of humans. It was originally used in a play where millions were manufactured to work as slaves in factories. Most robots today don't really appear to be human-like, but they do the work of many humans, mostly in industry. Robots today weld car bodies together, diffuse bombs, perform surgery, help the handicapped and even explore other planets.

## **Changes in the Environment also result in new technologies being developed**

Since the early 1960's the environment has impacted technological development because people wanted to repair the negative impacts they had made on the environment. New technologies (like recycling) were needed to prevent more damage. Processing materials over and over or making them biodegradable would address some of the issues. Other technologies (like oil skimmers) helped make environmental clean-up more effective and prevent further damage.

## Mechanical Systems

### Topic 7 – Machines through History Practice Quiz

1. In early times, people with buckets usually transported water from one place to another. A scientist later invented a device to make it easier, which used the motion of a simple machine. The device was called ...
  - A. Achilles water wheel
  - B. Achilles pulley
  - C. Archimedes wedge
  - D. Archimedes screw
  
2. An important milestone invention in the eighteenth century led to many changes in transportation technology. It was the invention of the ...
  - A. Steam engine
  - B. Internal combustion engine
  - C. Hydraulic lift
  - D. Water wheel
  
3. 'Paddle Wheelers' were common sites at one time on many rivers in North America. The machinery that moves the wheel, which propels the boat forward is powered by ...
  - A. Gasoline
  - B. Air
  - C. Water
  - D. Steam
  
4. Nowadays, a rotary engine is used to propel an ocean liner. The main difference between a rotary engine and a steam engine is that in a rotary engine the steam doesn't propel the piston, but turns the ...
  - A. Rudder
  - B. Turbine
  - C. Housing
  - D. Cylinder
  
5. The internal combustion engine was developed in 1776. The engine works because of the combustion that takes place inside the engine. The combustion is fueled by ...
  - A. Gasoline
  - B. Water
  - C. Electricity
  - D. Air

## Topic 8 – People and Machines

Science and technology have given us many different amazing machines that have made our daily tasks easier. The automobile caught on very quickly, but the ideal machine soon demonstrated its greatest flaw. Pollution of the environment was a result of more and more fossil fuels being burned, in larger vehicles. Improving machines brought lots of positives, but there were also some negative side effects (like pollution).

### The Industrial Revolution

The invention of the steam engine transformed society. Simple machinery replaced hand labor since 1700. Water-driven spinning machines were used in 1769 and could do the work of 12 workers. James Watt's efficient steam engine and Henry Cort's use of coal for fuel (instead of wood) to make iron started the Industrial Revolution.



*Mass production* industries began and soon small towns became industrialized cities, leading to social change.

People flocked to the cities to get work in the factories – the shift from rural living to urban dwellers began.



### Which Came First?

The question of whether technology changes society or society changes technology is still a challenge today. The automobile uses cheap fuel and therefore more vehicles are being used. With cities so large, people need a vehicle to travel from place to place. OR, is the convenience of having a vehicle just societies' reason to have larger cities?

Because of the impact of scientific knowledge on society preferences for styles and sizes of vehicles changed. Larger vehicles polluted more and cost more to operate, so society wanted more compact fuel efficient vehicles. Today alternative fuel sources (solar-powered, electricity, hybrids, propane and hydrogen fuel cells) are being tested and are utilized to a very small extent.

### What Is It For?

When a new technology is being designed or an old technology improved upon the starting point must be the function – what is it that you want the technology to do? Scientists often have to ask themselves difficult questions, weighing the positive and negative effects of the technology. The ethical issues must be reviewed and considered in the decision to go ahead. Nuclear power is just one example – clean and efficient power generation VS nuclear accidents can devastate the environment. Consumers must also make smart choices when purchasing goods or services. Certain considerations must be taken into account, including how much energy is needed to make the goods or services available?

### Designing for Comfort

How do inventors use their understanding of scientific concepts to design a new device, or modify an old one? Many of the principles of design rely on the physics principles of Force, Area and Pressure (Topic 4).

### The Science of Comfort

The science of ergonomics was introduced in Topic 1. The testing systems that designers use provide scientific information to researchers, allowing them to decide what type of modification is best for its designed purpose. Comfort is an important criterion that is evaluated.

The wheelchair has gone through many improvements over the years. These changes happened because of the research into ergonomic designs and pressure put on the designers by the consumer.



## Mechanical Systems

### Topic 8 – People and Machines Practice Quiz

1. Science and technology have given us many improvements in transportation. One of the most notable was the development of the 'horseless carriage', which was ...
  - A. Scooter
  - B. Segway
  - C. Automobile
  - D. Train
2. The Industrial Revolution enabled people to build many machines in a short period of time. This meant that more people could get these machines. The manufacturing process that made this possible was called ...
  - A. Mass hysteria
  - B. Mass production
  - C. Industrial efficiency
  - D. International exports
3. Automobiles have continued to improve over the years. The improvements in fuel-efficiency and better gas mileage have come as a result of the invention and wide spread use of ...
  - A. Bigger engines and aerodynamics
  - B. Hydrogen and water power
  - C. Fuel-injection and catalytic converters
  - D. Urban renewal and urban sprawl
4. Machines have changed over time because of the purpose for which it is being used. Scientists ask themselves some difficult questions, including ...
  - A. How much is it going to cost?
  - B. Why should it be changed?
  - C. How difficult is it going to be to improve it?
  - D. What are the pros and cons?
5. When scientists discover a way to improve a device's comfort or efficiency, they are tested. This testing provides additional scientific information to the designers. The research activity which analyzes improvements in the comfort is referred to the 'science of ...'
  - A. Modification
  - B. Pneumatics
  - C. Ergonomics
  - D. Hydraulics

## Mechanical Systems Summary & Review

<p>What do we use machines to do work and to transfer energy?          How can we design and use machines efficiently and responsibly?          How have machines changed over time?</p>	
Key Concepts Science Focus 8 (Unit At A Glance p. 356)	Guiding Questions and Activities to Help you Study
<b>Topic 1</b> Levers and Inclined Planes	<ul style="list-style-type: none"> <li>- Describe the various types of simple machines. (additional notes) -</li> <li>- Explain the differences between the three different class levers. (p. 271) -</li> <li>- Know the scientific meaning of Work and how to calculate it. (p. 276)</li> <li>- How do machines make work easier? (p.278)</li> </ul>
<b>Topic 2</b> The Wheel and Axle, Gears, and Pulleys	<ul style="list-style-type: none"> <li>- What is Mechanical Advantage and how is it calculated? (p.278-281)</li> <li>- Explain how machines can be designed and adapted to meet the specific needs of people. (p.283) - Describe what a winch is. (p. 285)</li> <li>How does a wheel and axle work? (p. 286)</li> <li>- Illustrate different gear ratios and combinations of gears. (notes, p. 287-289)</li> <li>- Describe how pulleys are used to change the direction of motion when objects are lifted. (p 292-293) - Illustrate different kinds of pulleys and practical applications for each. (p 292-293)</li> </ul>
<b>Topic 3</b> Energy, Friction and Efficiency	<ul style="list-style-type: none"> <li>- Describe the difference between potential and kinetic energy. (p.296) -</li> <li>- How do machines transfer energy? (p 298) - What does friction do to efficiency in a machine? (p.298-299)</li> </ul>
<b>Topic 4</b> Force, Pressure and Area	<ul style="list-style-type: none"> <li>- What happens when you change the area over which force is applied? (p.304) - Provide some practical applications, which use the principle of 'spreading force over a larger area', to reduce the pressure. (p.305)</li> <li>- Describe Pascal's law and give practical examples, which apply the law. (p.307-309)</li> </ul>
<b>Topic 5</b> Hydraulics and Pneumatics	<ul style="list-style-type: none"> <li>- Explain the difference between hydraulics and pneumatics. (p.313) -</li> <li>- Create a comparison chart that illustrates the similarities and differences between open (pneumatic) and closed (hydraulic) systems. Identify practical everyday situations in which hydraulics and pneumatics are used to make work easier. (p 314-318)</li> <li>- Describe where hydraulics and pneumatics can be found in your body. (p.323-325)</li> </ul>
<b>Topic 6</b> Combining Systems	<ul style="list-style-type: none"> <li>- Describe how large machines (systems), are created by combining simple machines (subsystems). (p.326-330)</li> </ul>
<b>Topic 7</b> Machines throughout History	<ul style="list-style-type: none"> <li>- Illustrate a timeline of transportation machines throughout history (p.332-341)</li> </ul>
<b>Topic 8</b> People and Machines	<ul style="list-style-type: none"> <li>- How does society change the way machines are developed and used? (p.342-343) - What impacts do machines have on people and the environment (p.344-346) - What reasons are there to develop better machines by using science and technology? (p 348)</li> <li>- What is the science of ergonomics? (p. 349)</li> </ul>
<p>Design a Concept Map linking the ideas introduced and reinforced in this Unit on Cells and Systems</p>	

## Unit 4 – Mechanical Systems – Year End Review

Complete each of the following questions, relating to the specific learner outcomes, covered this year in Grade 8. The questions in this review reflect what you should have mastered and will be tested on in the Final Achievement Exam. The answers will be covered in class.

### Part 1 – Simple Machines

Describe different **simple machines**.

---



---



---



---



---



---



---

Explain how simple machines help people perform tasks easier.

---



---



---

Identify the **3 different classes of levers**. (p. 271)

Class 1	Class 2	Class 3
Examples	Examples	Examples

What is **work**? (p. 276)

---

---

How is work **calculated**? (p. 276)

Explain why machines make '**work**' easier.

---

---

## Part 2 – Mechanical Advantage

What is **mechanical advantage**? (p. 278)

---

---

How is mechanical advantage **calculated**?

How can machines be **adapted** to suit specific needs? (p.283)

---

---

What is **ergonomics**? (p.283)

---

---

**Part 3 – Pulleys**

Describe the different **types of pulleys** and give examples of each.

---

---

---

---

What is a **winch** and how does it work?

---

---

What is a **wheel and axle** and how does it work?

---

---

What are **gears** and how do they work?

---

---

---

What is a **gear train**? (Illustrate an example)

---

---

---



Illustrate different **types of gears**.

<b>Driver gear</b>	<b>Follower gear</b>
<b>Multiplying gears</b>	<b>Reducing gear</b>
<b>Wheel and pinion</b>	<b>Chain and sprockets</b>

#### Part 4 – Energy Transformation and Transmission in Machines

Describe the difference between **potential** and **kinetic** energy.

---



---

How is energy **transformed** in a machine?

---



---

How is energy **transferred** in a machine?

---



---

How do **frictional forces** affect the operation and **efficiency** of a machine?

---

---

---

What is '**waste energy**'? (p.36)

---

---

**Part 5 – Pressure**

What is **pressure**? (p. 40)

---

---

How is pressure **calculated**?

---

---

What devices use the **pressure principle**? (p. 48-49)

---

---

---

What is **Pascal's Law**?

---

---

What happens when a fluid is **compressed**?

---

---

What are **hydraulic systems**?

---

---

What **devices** use hydraulic systems? (Explain how)

---

---

---

---

What are **pneumatic systems**?

---

---

What **devices** use pneumatic systems? (Explain how)

---

---

---

---

What is a **subsystem**?

---

---

---

---

---



## Mechanical Systems Unit 4 Test

---

Student \_\_\_\_\_ Class \_\_\_\_\_

1. A wheelbarrow is an example of what simple machine?
  - A Class 1 lever
  - B Class 2 lever
  - C Class 3 lever
  - D Wheel and Axle
  
2. A hockey stick is an example of what simple machine?
  - A Class 1 lever
  - B Class 2 lever
  - C Class 3 lever
  - D Inclined plane
  
3. Scissors are an example of what simple machine?
  - A Class 1 lever
  - B Class 2 lever
  - C Class 3 lever
  - D Wedge
  
4. A teeter-totter an example of what simple machine?
  - A Class 1 lever
  - B Class 2 lever
  - C Class 3 lever
  - D Inclined plane
  
5. A simple machine that converts rotational motion to linear motion is called ...
  - A Class 1 lever
  - B Inclined plane
  - C Wedge
  - D Screw
  
6. A diving board is an example of what simple machine?
  - A Class 1 lever
  - B Class 2 lever
  - C Class 3 lever
  - D Inclined plane

7. The Canadarm is an example of what simple machine?

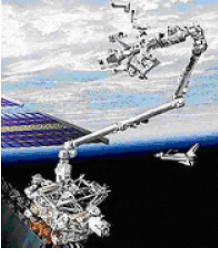

- A. Class 4 Lever
- B. Class 3 Lever
- C. Class 2 Lever
- D. Class 1 Lever

(Use the following diagram for the next question)



8. In the lever above, the Effort Force is applied at E. This makes it a ...
- A 1st Class lever
  - B 2nd Class lever
  - C 3rd Class lever
  - D 4th Class lever
9. Work is energy in action. It is measured in ...
- A N/m (Newtons per meter)
  - B P.s.i (Pounds per square inch)
  - C J (Joules)
  - D Kg\*m (Kilograms times meters)
10. Mechanical Advantage is the comparison of the force produced by a machine to the force applied to the machine. The formula used to calculate it is  $MA = FL / FE$ . Use the formula to calculate the mechanical advantage to lift an SUV with a tree branch, acting as a 1st Class lever. The effort force applied to the tree branch is 500 N and the SUV weighs 5000 N. The mechanical advantage of the lever is ...
- A 10
  - B 0.10
  - C 4500
  - D 5500
11. Calculate the mechanical advantage, when 736 N of force is used on a bicycle pedal, causing 81 N of force to move the bicycle forward.
- A 917
  - B 655
  - C 9.08
  - D 0.11

12. It takes 120N of force to raise the flag up the flagpole. The load is 120N. What is the mechanical advantage? ...
- A 0
  - B 1
  - C 120
  - D 240
13. The Mechanical Advantage of a lever can also be calculated using this formula ...  $MA = \text{Effort Arm} / \text{Load Arm}$  (Reread question #10) If the length of the branch between the effort and the fulcrum is 3m and the length of the branch from the fulcrum to the SUV is 0.3 m, what is the mechanical advantage of the lever?
- A 0.1
  - B 2.7
  - C 3.3
  - D 10
14. Hockey players realize that the advantage of using a hockey stick, as a 3rd Class lever, is that the force they apply to the puck will move it ...
- A with more accuracy
  - B a shorter distance
  - C with more force
  - D faster
15. The science of designing machines to suit people is called ergonomics. The primary criteria used in designing a machine ergonomically are ...
- A expense
  - B aesthetics
  - C comfort
  - D size
16. A device that consists of a small cylinder, with a handle or a crank, is called a ...
- A radius
  - B winch
  - C fulcrum
  - D pinion
17. Gears are used in combination, with the teeth of the gears interlocking, so when one moves the other moves as well. Effort can be applied to the first gear (24 teeth), with the resulting effect on the second gear (12 teeth) being a ...
- A speed advantage of 0.5
  - B speed advantage of 2
  - C force advantage of 2
  - D force advantage of 0.5

18. When gears are used in a gear train, the resulting effect is that each gear travels ...
- A slower than the one next to it
  - B faster than the one next to it
  - C in an opposite direction than the one it is nearest to
  - D always in the same direction as the one next to it
19. A bicycle an example of gears that don't have to be touching one another to work together. This is possible because of a chain that connects the gears. This chain has links in it that fit into the teeth of the gears. A gear that has teeth that fit into the links of a chain is called a ...
- A sprocket
  - B sprigget
  - C driving gear
  - D follower gear
20. The mechanical advantage of the block and tackle (complex combination of fixed and moveable pulleys) pictured here is ...

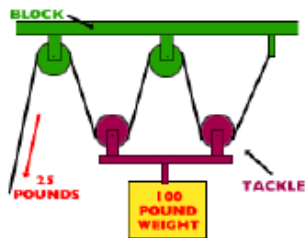

- A 3
  - B 4
  - C 5
  - D 6
21. Using the gear train illustrated here to answer this question

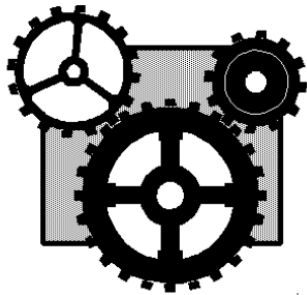

Identify the direction and speed of the 2nd follower gear if the driven gear is the 1st gear on the left and it is being turned clockwise ...

- A clockwise with a speed ratio of 1.34
- B counterclockwise with a speed ratio of 1.34
- C clockwise with a speed ratio of 2
- D counterclockwise with a speed ratio of 2



22. The pedals on a bicycle are attached to sprocket gears which are linked together by a chain. The type of energy that describes the motion created when you apply force to the pedal is ...
- A gravitational
  - B frictional
  - C potential
  - D kinetic
23. ( Efficiency = work output / work input ) A pulley system lifts a 100N load with a force of 20N. The input distance is 3m and the output distance is 0.5m. The efficiency of this pulley system is ...
- A 62.5%
  - B 75.0%
  - C 83.3%
  - D 92.75%
24. Efficiency can be increased by reducing frictional force. A sport that tries to reduce frictional force by sweeping the ice in front of the rock is ...
- A cycling
  - B curling
  - C rock climbing
  - D ice sculpturing
25. When a skater moves across an ice surface, a thin layer of water is created, allowing the skate blade to slide across the surface with little friction. This layer of water is produced by the pressure of the....
- A zamboni
  - B atmosphere
  - C skate blade
  - D ice temperature
26. To calculate pressure the formula used is  $P = F / A$ . Units of pressure are ...
- A joules
  - B kilojoules
  - C pascals
  - D kilograms
27. The heel of a stiletto shoe can exert a lot of pressure. If the area of the heel is 0.5cm<sup>2</sup> and a force of 200N is exerted using the heel, what is the pressure exerted by the heel?
- A 10 Pa
  - B 200 Pa
  - C 400 Pa
  - D 1000 Pa

28. Crash test dummies are used to test safety in vehicles. The reason for this is because they are....
- A inexpensive to use
  - B realistic
  - C easily repaired
  - D non-living
29. Pascal's law states that ...
- A pressure exerted on a contained fluid is transmitted equally in all directions
  - B force exerted on a contained fluid is transmitted equally in all directions
  - C hydraulics exerted on a contained fluid is transmitted equally in all directions
  - D pneumatics exerted on a contained fluid is transmitted equally in all directions
30. A cherry picker uses hydraulics to raise a working platform. 10N of force are applied to the small piston in the hydraulic system to raise a load of 50N (on the large piston) a distance of 0.5m. How far would the small piston have to be pushed to accomplish this task?
- A 5 m
  - B 2.5 m
  - C 0.5 m
  - D 25 m
31. If the area of the small piston on the left is  $0.5\text{m}^2$  and the area of the large piston is  $5.5\text{m}^2$ ,

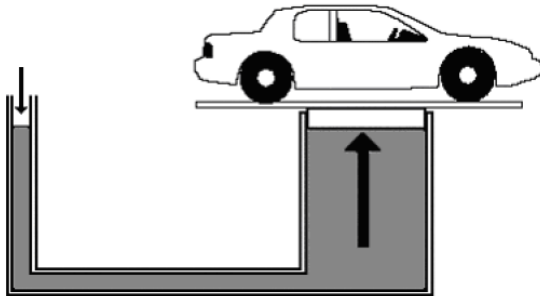

- The mechanical advantage of the illustrated hydraulic lift here would be ...
- A 1.1
  - B 6.0
  - C 2.5
  - D 11
32. In the hydraulic lift from the previous question (Question # 31) the advantage is force and the disadvantage is...
- A pressure
  - B speed
  - C distance
  - D compression

33. In early times, people with buckets usually transported water from one place to another. A scientist later invented a device to make it easier, which used the motion of a simple machine. The device was called ...
- A Achilles ramp
  - B Achilles pulley
  - C Archimedes wedge
  - D Archimedes screw
34. During the research phase, when a device is improved upon, certain criteria are taken into account. Of the criteria listed below, which would be the least important ...
- A safety
  - B efficiency
  - C effectiveness
  - D convenience
35. Comfort is an important consideration when designing a machine or improving upon an existing machine. The science that designs machines for comfort is called ...
- A bionics
  - B economics
  - C ergonomics
  - D meganomics
36. Use the illustration, of a hydraulic disc brake system, below to answer the question.

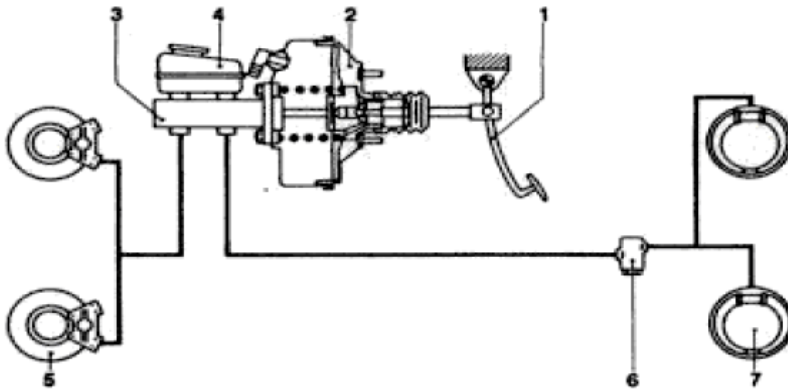

The effort force required to slow the vehicle in this disc brake hydraulic system would be applied at number ...

- A 1
- B 3
- C 5
- D 7

Complete the **Numerical Response** Questions that follow

**NR1**- A block and tackle pulley system is used to lift heavy machinery in the CTS room. One machine is 223 kg. To lift it into place where it is going to be used, it has to be raised 1.2m off the floor.

How much work is being done to raise the machine onto its platform?  
(Show your work)

	.	.	
0	0	0	0
1	1	1	1
2	2	2	2
3	3	3	3
4	4	4	4
5	5	5	5
6	6	6	6
7	7	7	7
8	8	8	8
9	9	9	9

**NR2** - To test the success of a protective egg carton (which has a mass of 200g), Jacobs (who has a mass of 60kg), carried it up to the roof. It was dropped from a height of 4m.

How much work was done by Jacobs to test the egg protection device?  
(Show your work)

	.	.	
0	0	0	0
1	1	1	1
2	2	2	2
3	3	3	3
4	4	4	4
5	5	5	5
6	6	6	6
7	7	7	7
8	8	8	8
9	9	9	9

**NR3** - The pulley system illustrated here was used to lift a heavy load.



If 340N of force is used, how much force is the pulley system able to overcome?

(Show your work)

	.	.	
0	0	0	0
1	1	1	1
2	2	2	2
3	3	3	3
4	4	4	4
5	5	5	5
6	6	6	6
7	7	7	7
8	8	8	8
9	9	9	9

**NR4** -The work done by a lever is 5225J. The work done by the effort force is 8650J.

What is the efficiency of the lever?  
(Show your work)

	.	.	
0	0	0	0
1	1	1	1
2	2	2	2
3	3	3	3
4	4	4	4
5	5	5	5
6	6	6	6
7	7	7	7
8	8	8	8
9	9	9	9

**NR5** - Your grandfather gave you his bicycle. As you push down on the pedals you find that you are exerting 797N of force. The resulting load force causing the bicycle to move forward is 104N.

What is the mechanical advantage of the bicycle?  
(Show your work)

	.	.	
0	0	0	0
1	1	1	1
2	2	2	2
3	3	3	3
4	4	4	4
5	5	5	5
6	6	6	6
7	7	7	7
8	8	8	8
9	9	9	9

**NR6** - A hydraulic lift was used to lift a load of 264N up three shelves high in a warehouse. The operator found that the distance it moved was 3.2m. If the mechanical advantage of the hydraulic lift was 10.

How much effort force was needed to lift the load?  
(Show your work)

	.	.	
0	0	0	0
1	1	1	1
2	2	2	2
3	3	3	3
4	4	4	4
5	5	5	5
6	6	6	6
7	7	7	7
8	8	8	8
9	9	9	9

## Science Focus 8

### Mechanical Systems Practice Quiz - Answer Keys

	Question 1	Question 2	Question 3	Question 4	Question 5	Question 6
Topic 1	B	C	C	C	C	D
Topic 2	B	B	C	B	D	
Topic 3	C	B	C	C	B	
Topic 4	C	C	D	A	B	
Topic 5	D	B	D	B	A	
Topic 6	A	D	C	B	C	
Topic 7	D	A	D	B	A	
Topic 8	C	B	C	D	C	

### Mechanical Systems Unit Test - Answer Key

1	B	11	D	21	A	31	D
2	C	12	B	22	D	32	C
3	A	13	D	23	C	33	D
4	A	14	D	24	B	34	D
5	D	15	C	25	C	35	C
6	A	16	B	26	C	36	A
7	B	17	B	27	C		
8	C	18	C	28	D		
9	C	19	A	29	A		
10	A	20	B	30	B		

NR1	NR2	NR3	NR4	NR5	NR6
2676	2408	1020	60.4	0.13	26.4